

●最大额定值 (TC=25°C)

● Absolute Maximum Ratings (Tc=25°C)

TO-220/220FP/262/263

参数 PARAMETER	符号 SYMBOL	额定值 VALUE	单位 UNIT
漏-源电压 Drain-source Voltage	V_{DS}	650	V
栅-源电压 gate-source Voltage	V_{GS}	± 30	V
漏极电流 Continuous Drain Current TC=25°C	I_D	5.0	A
漏极电流 Continuous Drain Current TC=100°C	I_D	3.15	A
最大脉冲电流 Drain Current – Pulsed ①	I_{DM}	20	A
耗散功率 Power Dissipation	P_{tot}	TO-220:120	W
		TO-220FP:50	
		TO-262/263:120	
最高结温 Junction Temperature	T_j	150	°C
存储温度 Storage Temperature	T_{STG}	-55-150	°C
单脉冲雪崩能量 Single Pulse Avalanche Energy ②	E_{AS}	210	mJ

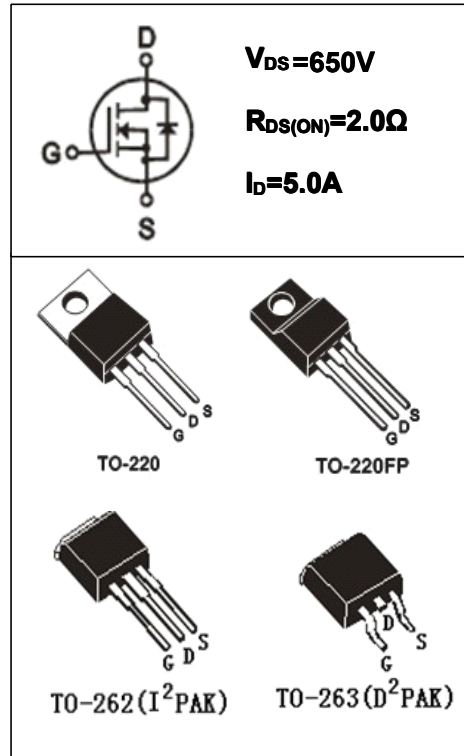

●电特性 (Tc=25°C)

● Electronic Characteristics (Tc=25°C)

参数 PARAMETER	符号 SYMBOL	测试条件 TEST CONDITION	最小值 MIN	典型值 TYP	最大值 MAX	单位 UNIT
漏-源击穿电压 Drain-source Breakdown Voltage	BV_{DSS}	$V_{GS}=0V, I_D=250\mu A$		650		V
击穿电压温度系数 Breakdown Voltage Temperature Coefficient	$\Delta BV_{DSS}/\Delta T_j$	$I_D=250\mu A$, Referenced to 25°C		0.6		V/°C
栅极开启电压 Gate Threshold Voltage	$V_{GS(TH)}$	$V_{GS}=V_{DS}, I_D=250\mu A$	2.0		4.0	V
漏-源漏电流 Drain-source Leakage Current	I_{DSS}	$V_{DS}=650V,$ $V_{GS}=0V, T_j=25^\circ C$			10	μA
		$V_{DS}=480V,$ $V_{GS}=0V, T_j=125^\circ C$			100	μA
跨导 Forward Transconductance	g_{fs}	$V_{DS}=40V, I_D=2.5A$ ③		4.0		S

参数 PARAMETER	符号 SYMBOL	测试条件 TEST CONDITION	最小值 MIN	典型值 TYP	最大值 MAX	单位 UNIT
栅极漏电流 Gate-body Leakage Current ($V_{DS} = 0$)	I_{GSS}	$V_{GS} = \pm 30V$			± 100	nA
漏-源导通电阻 Static Drain-source On Resistance	$R_{DS(ON)}$	$V_{GS} = 10V, I_D = 2.5A$ ①		1.5	2.0	Ω
输入电容 Input Capacitance	C_{iss}	$V_{GS} = 0V, V_{DS} = 25V$ $F = 1.0MHz$		730		pF
输出电容 Output Capacitance	C_{oss}			25		
反向传输电容 Reverse transfer Capacitance	C_{rss}			16		
关断延迟 Turn -Off Delay Time	$T_d(off)$	$V_{DD} = 300V, I_D = 5.0A$ $R_G = 25\Omega$ ②		38		ns
栅极电荷 Total Gate Charge	Q_g	$I_D = 5.0A, V_{DS} = 480V$ $V_{GS} = 10V$ ③		15		nC
栅源电荷 Gate-to-Source Charge	Q_{gs}			3.7		nC
栅漏电荷 Gate-to-Drain Charge	Q_{gd}			4.8		nC
二极管正向电流 Continuous Diode Forward Current	I_S				5.0	A
二极管正向压降 Diode Forward Voltage	V_{SD}	$T_j = 25^\circ C, I_S = 5.0A$ $V_{GS} = 0V$ ②			1.4	V
反向恢复时间 Reverse Recovery Time	t_{rr}	$T_j = 25^\circ C, I_f = 5.0A$ $di/dt = 100A/\mu s$ ③		270		ns
反向恢复电荷 Reverse Recovery Charge	Q_{rr}			1.9		μC

●热特性

● Thermal Characteristics

参数 PARAMETER	符号 SYMBOL	最大值 MAX			单位 UNIT
		TO-220	TO-220FP	TO-262/263	
热阻结-壳 Thermal Resistance Junction-case	R_{thJC}	1.04	2.50	1.04	$^\circ C/W$
热阻结-环境 Thermal Resistance Junction-ambient	R_{thJA}	62.5	62.5	62.5	$^\circ C/W$

注释(Notes):

- ① 脉冲宽度：以最高节温为限制
Repetitive rating: Pulse width limited by maximum junction temperature
- ② 初始结温= $25^\circ C$, $V_{DD} = 50V$, $L = 18.9mH$, $R_G = 25\Omega$, $I_{AS} = 5.0A$
Starting $T_j = 25^\circ C$, $V_{DD} = 50V$, $L = 18.9mH$, $R_G = 25\Omega$, $I_{AS} = 5.0A$
- ③ 脉冲测试：脉冲宽度 $\leq 300\mu s$ ，占空比 $\leq 2\%$
Pulse Test : Pulse width $\leq 300\mu s$, Duty cycle $\leq 2\%$

● 特性曲线



图1 输出特性曲线, Tc=25°C

Fig1 Typical Output Characteristics, Tc=25°C

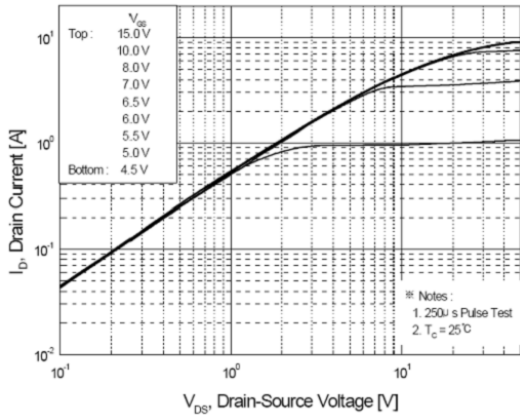

图2 导通电阻与漏极电流和栅极电压曲线

Fig2 On-Resistance Vs.Drain Current and Gate Voltage

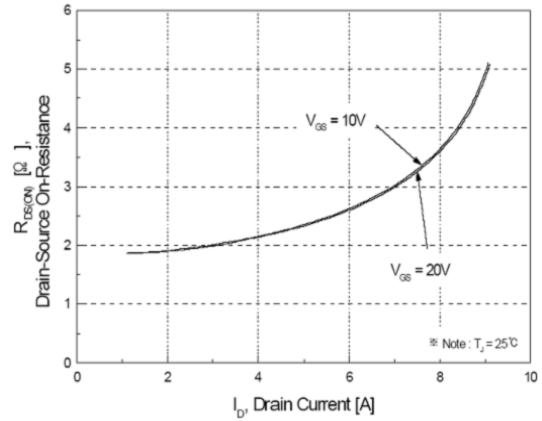

图3 导通电阻与温度曲线

Fig3 Normalized On-Resistance Vs.Temperature

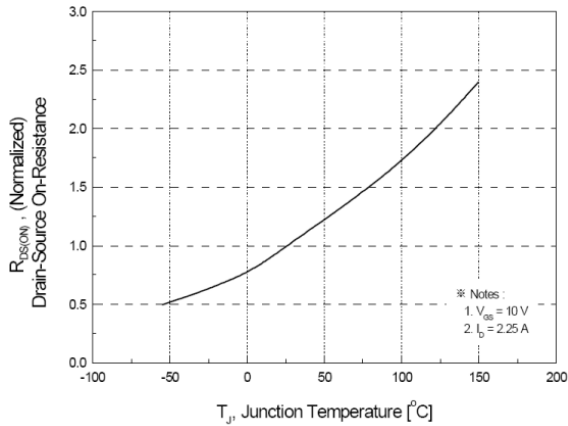

图4 二极管正向电压曲线

Fig4 Typical Source-Drain Diode Forward Voltage

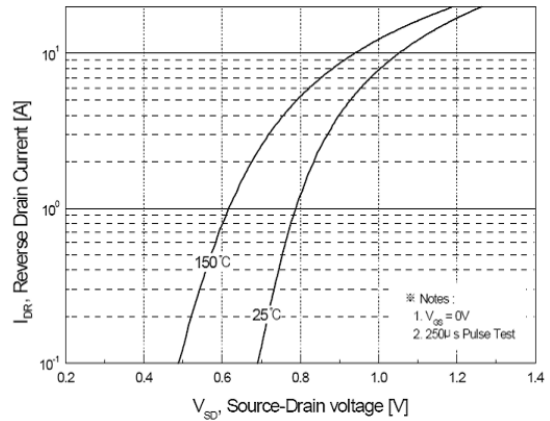

图5 最大漏极电流与壳温曲线

Fig5 Maximum Drain Current Vs.Case Temperature

● 特性曲线

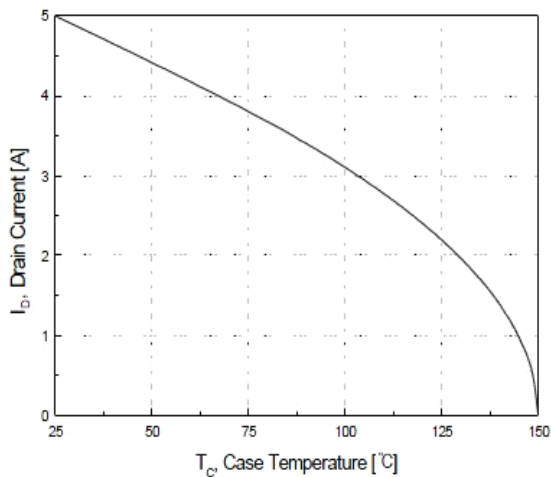

图 6-1 5N65(TO-220)

最大安全工作区曲线

Fig6-1 Maximum Safe Operating Area

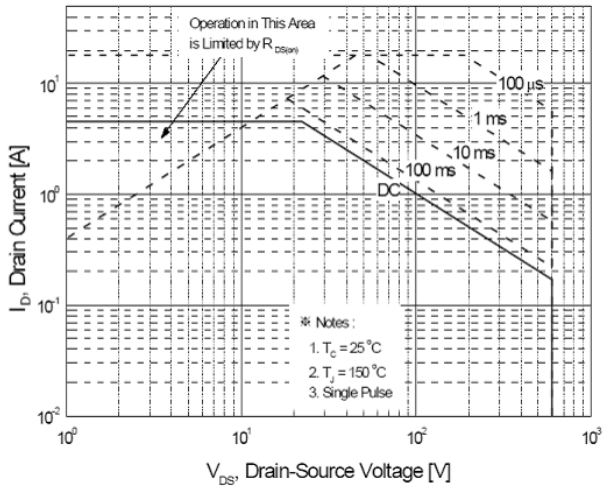

图 6-2 5N65(TO-220FP)

最大安全工作区曲线

Fig6-2 Maximum Safe Operating Area

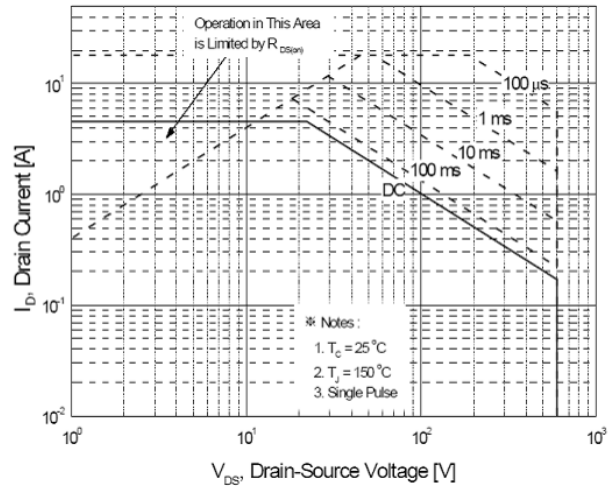

图 6-3 5N65(TO-262/263)

最大安全工作区曲线

Fig6-3 Maximum Safe Operating Area

TO-220 封装机械尺寸
TO-220 MECHANICAL DATA

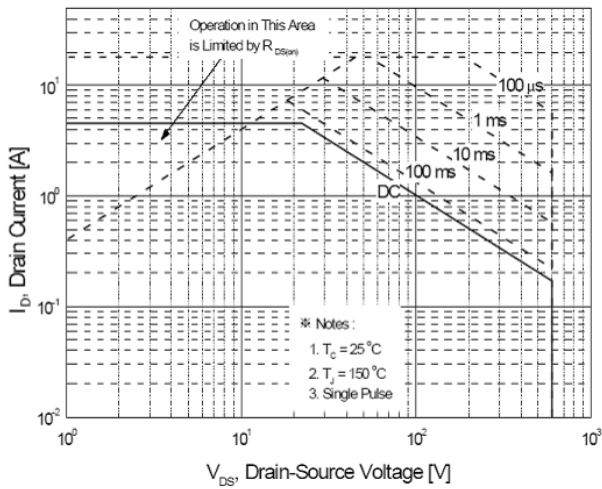
单位：毫米/UNIT: mm

符号 SYMBOL	最小值 min	典型值 nom	最大值 max	符号 SYMBOL	最小值 min	典型值 nom	最大值 max
A	4.00		4.80	E	9.90		10.70
B	1.20		1.50	e		2.54	
B1	1.00		1.40	F	1.10		1.45
b1	0.65		1.00	L	12.50		14.50
c	0.35		0.75	L1	3.00	3.50	4.00
D	15.00		16.50	Q	2.50		3.00
D1	5.90		6.90	Q1	2.00		3.00
				φP	3.60		3.90

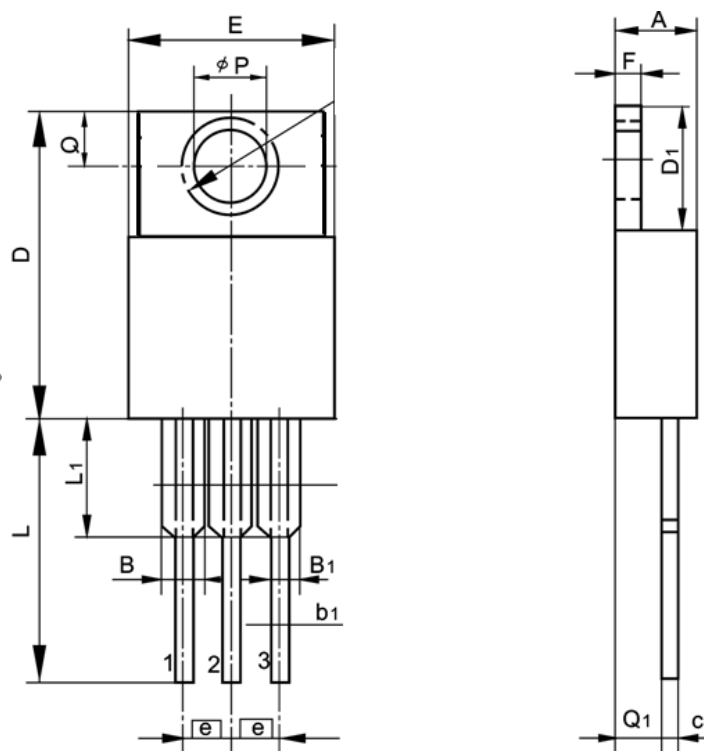

TO-220FP 封装机械尺寸
TO-220FP MECHANICAL DATA

单位:毫米/UNIT: mm

符号 SYMBOL	最小值 min	典型值 nom	最大值 max	符号 SYMBOL	最小值 min	典型值 nom	最大值 max
A	4.40		4.95	e		2.54	
A ₁	2.30		2.90	L	12.50		14.30
b	0.45		0.90	L ₁	9.10		10.05
b ₁	1.10		1.70	L ₂	15.00		16.00
c	0.35		0.90	L ₃	3.00		4.00
D	14.50		17.00	øp	3.00		3.50
D ₁	6.10		9.00	Q	2.30		2.80
E	9.60		10.30				

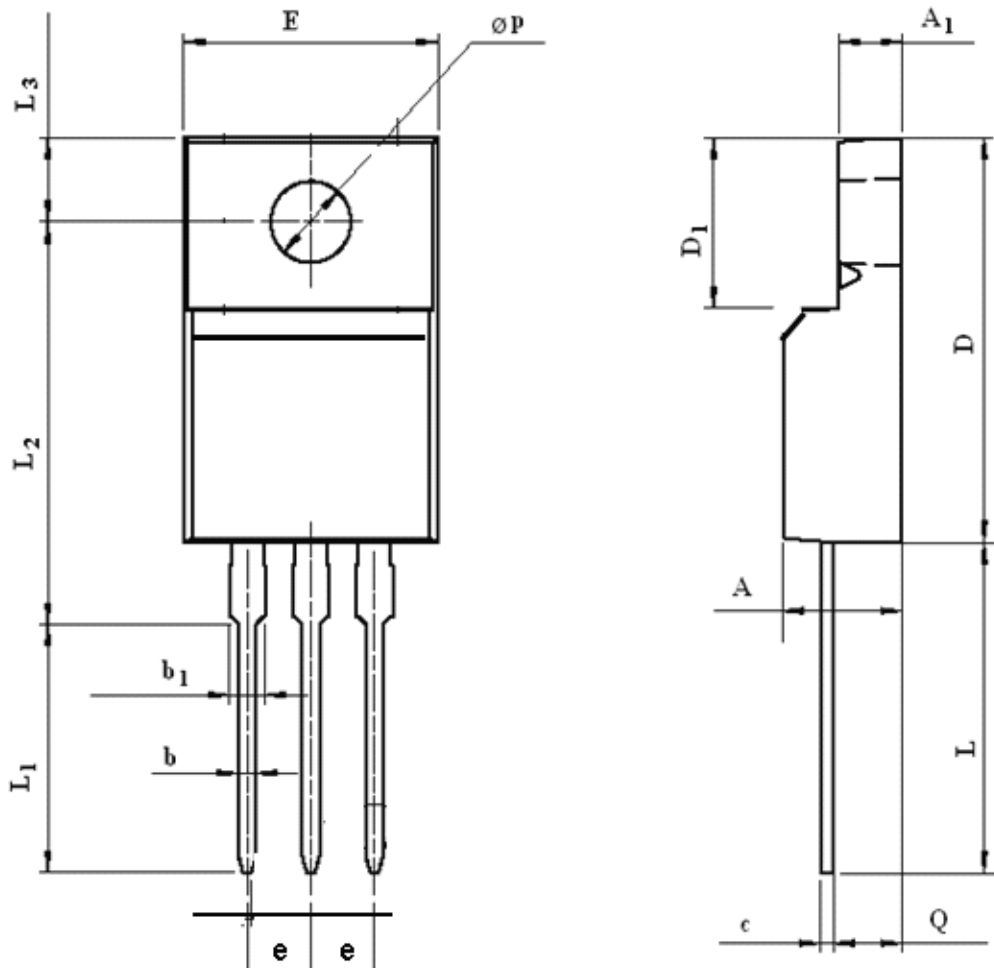

TO-262 封装机械尺寸
TO-262 MECHANICAL DATA

单位：毫米/UNIT: mm

符号 SYMBOL	最小值 min	典型值 nom	最大值 max	符号 SYMBOL	最小值 min	典型值 nom	最大值 max
A	3.80		4.80	e		2.54	
A1	2.00		2.80	e1			5.30
b	0.60		1.00	E	9.90		10.70
b1	1.20		1.40	L	12.50		14.50
c	0.40		0.70	L1	0.80	1.00	1.20
c2	1.10		1.40	L2			1.50
D			9.60				

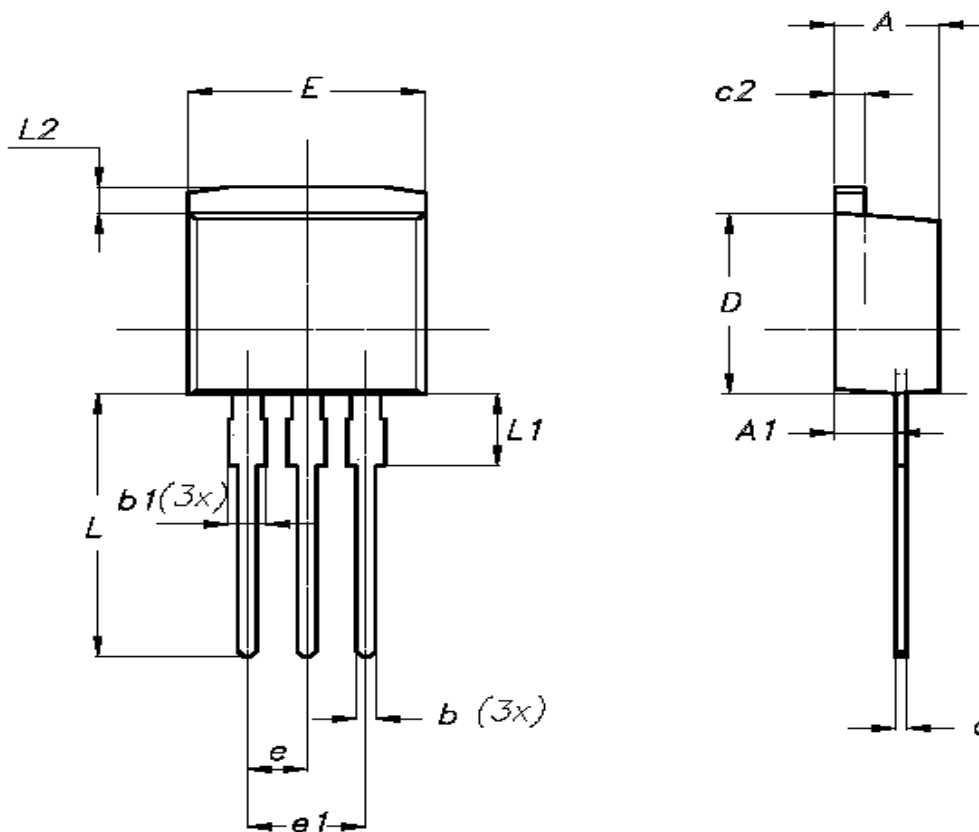

TO-263 封装机械尺寸
TO-263(D2PAK) MECHANICAL DATA

单位：毫米/UNIT: mm

符号 SYMBOL	最小值 min	典型值 nom	最大值 max	符号 SYMBOL	最小值 min	典型值 nom	最大值 max
A	4.42		4.72	E	8.99		9.29
B	1.22		1.32	e1	2.44		2.64
b	0.76		0.86	e2	4.98		5.18
b1	1.22		1.32	L1	15.19		15.79
b2	0.33		0.43	L2	2.29		2.79
C	1.22		1.32	L3	1.30		1.75
D	9.95		10.25				

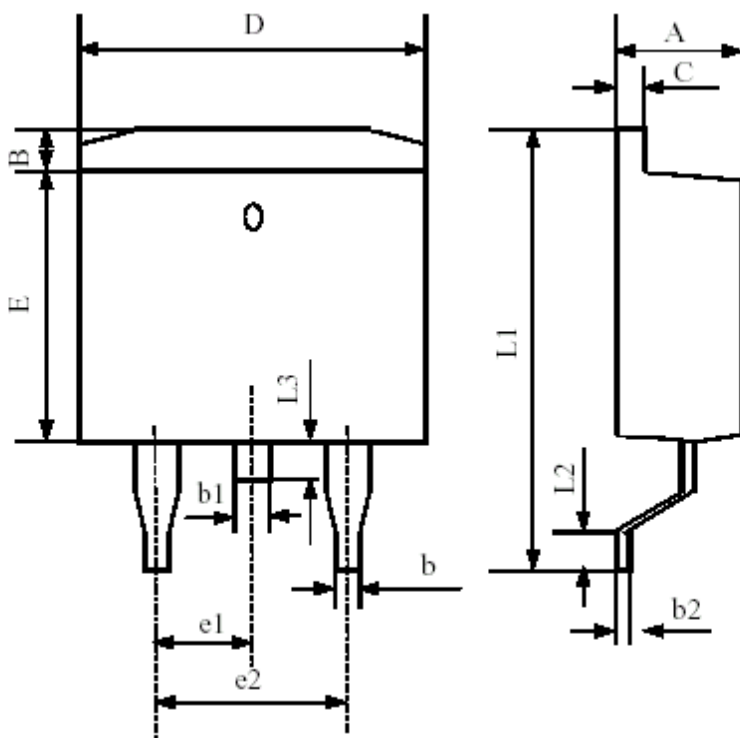

TO-263 编带规格尺寸
TO-263 TAPE AND REEL DATA

单位:毫米/UNIT: mm

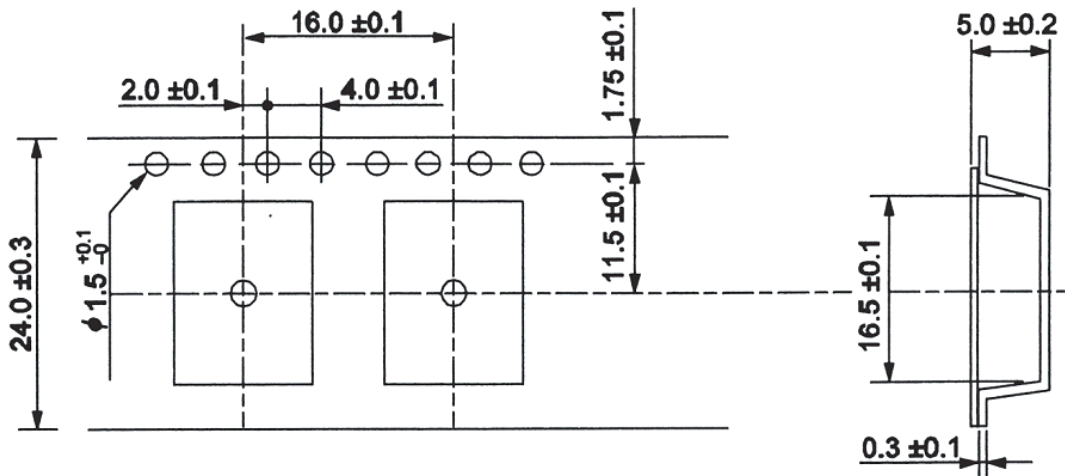

使用供带方向/USER DIRECTION OF FEED

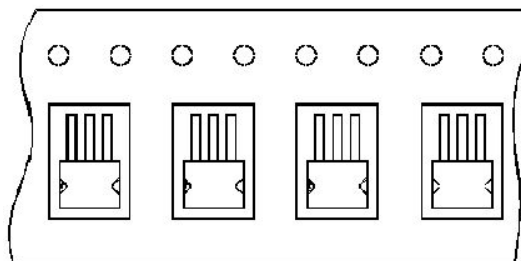

编带器件定位示意图/UNIT ORIENTATION